

PFNA-II

Proximal Femoral Nail Antirotation

Surgical Technique

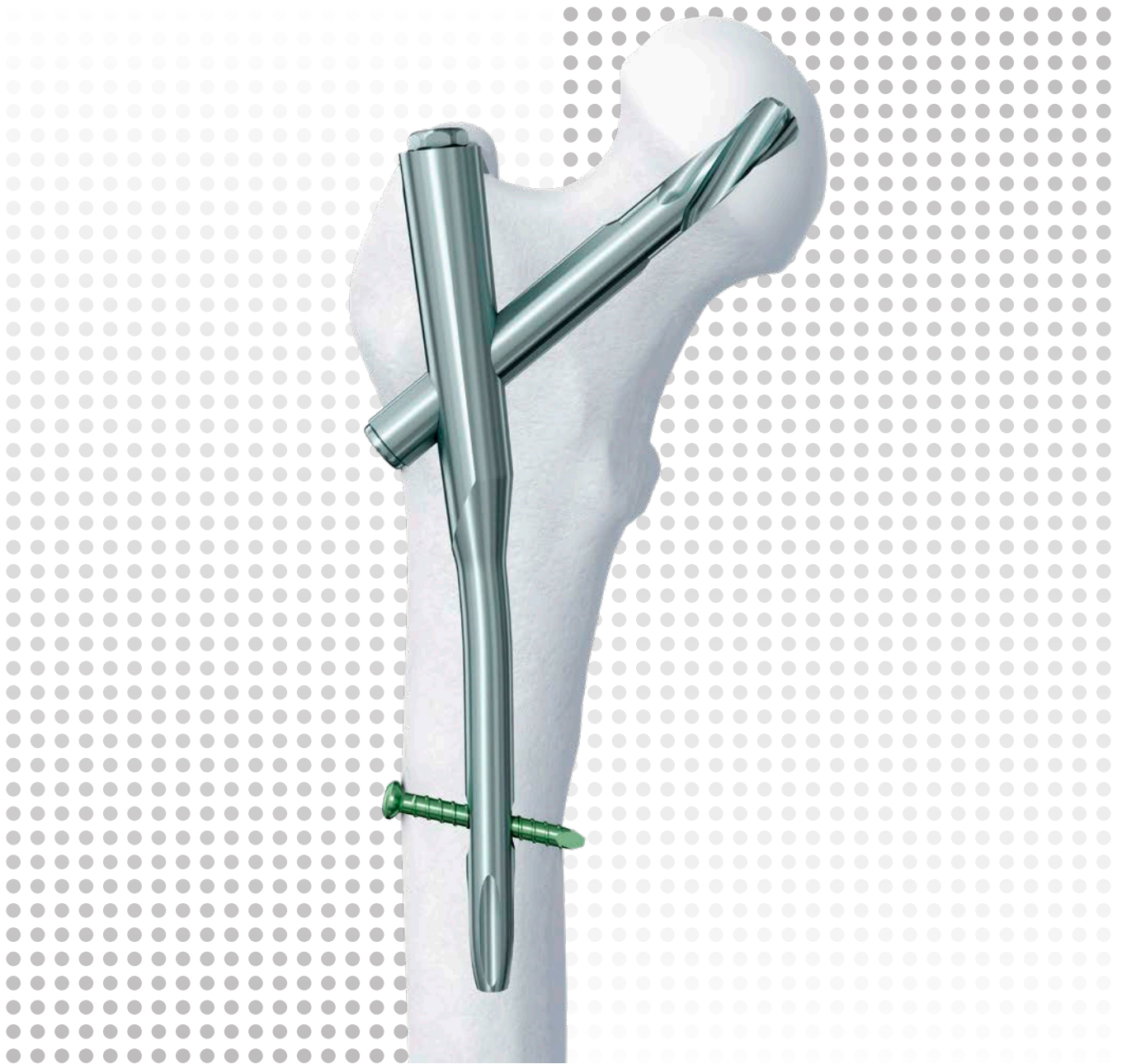

 Image intensifier control

This description alone does not provide sufficient background for direct use of DePuy Synthes products. Instruction by a surgeon experienced in handling these products is highly recommended.

Processing, Reprocessing, Care and Maintenance

For general guidelines, function control and dismantling of multi-part instruments, as well as processing guidelines for implants, please contact your local sales representative or refer to:

<http://emea.depuysynthes.com/hcp/reprocessing-care-maintenance>

For general information about reprocessing, care and maintenance of DePuy Synthes reusable devices, instrument trays and cases, as well as processing of DePuy Synthes non-sterile implants, please consult the Important Information leaflet (SE_023827) or refer to:

<http://emea.depuysynthes.com/hcp/reprocessing-care-maintenance>

Table of Contents

Introduction	PFNA-II Nail	2
	The AO Principles of Fracture Management	3
Surgical Technique	Preoperative Planning	4
	Patient Positioning	5
	Preparation	6
	Open Femur	10
	Insert Nail	15
	Proximal Locking	18
	Distal Locking	36
	• For PFNA-II Short	38
	• For PFNA-II Long	44
	Insert End Cap	47
	Implant Removal	49
	Broken Nail Removal	52
	Correction of Insertion Depth of PFNA-II Blade	56
	Cleaning	57
Product Information	Implants	58
	Alternative Implants	64
	Instruments	66
	Cases	75
MRI Information		79

- Notes
- ▲ Precautions
- ▲ WARNINGS

PFNA-II Nail

Product Range

The PFNA-II is available in 4 sizes

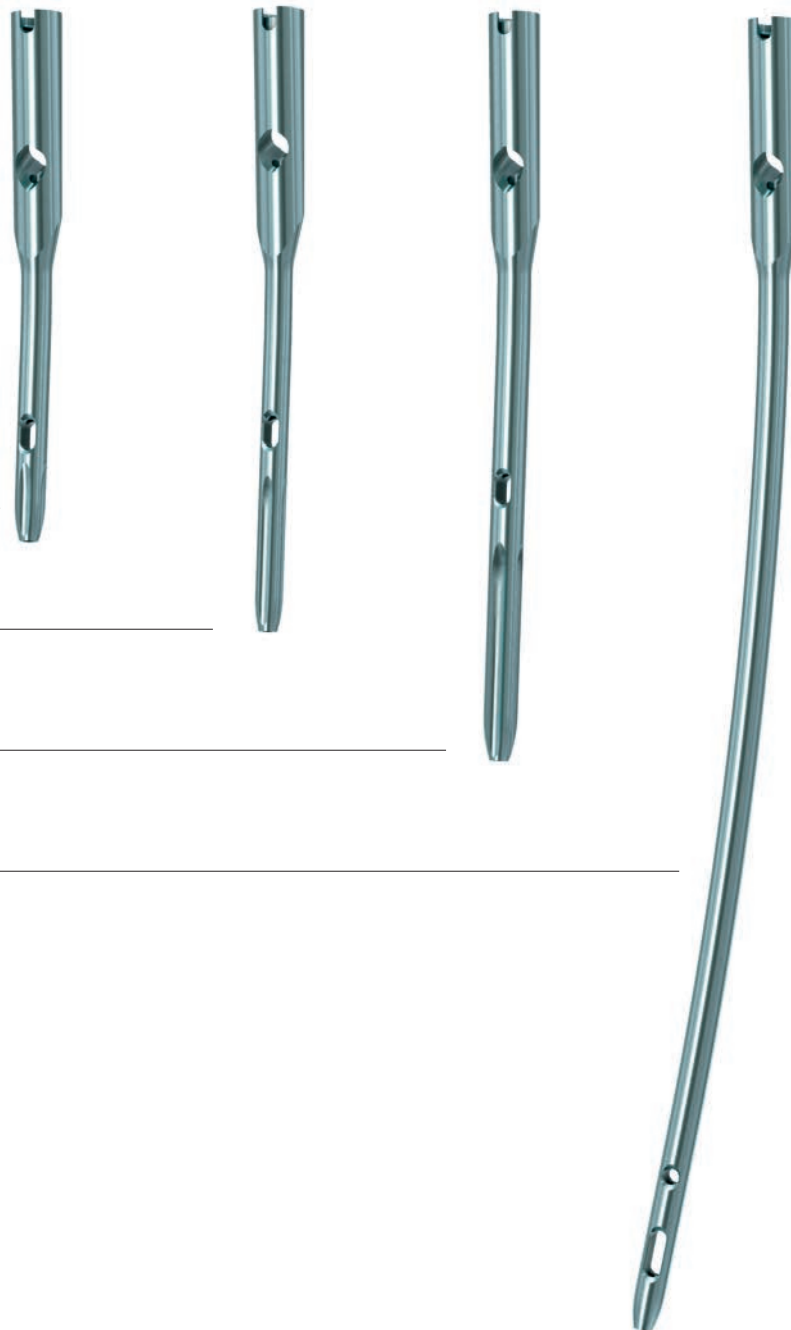

PFNA-II xs, length 170 mm

PFNA-II small, length 200 mm

PFNA-II, length 240 mm

PFNA-II long, length 260–340 mm
(with 20 mm increments), length 340–
420 mm (with 40 mm increments, only
Ø 10 mm nails), bending radius 1500 mm

Please refer to the corresponding Instructions for Use for specific information on Intended use, Indications, Contraindications, Warnings and Precautions, Potential Adverse Events, Undesirable Side Effect and Residual Risks. Instruction for Use are available at www.e-ifu.com and/or www.depuysynthes.com/ifu.

The AO Principles of Fracture Management

Mission

The AO's mission is promoting excellence in patient care and outcomes in trauma and musculoskeletal disorders.

AO Principles^{1,2}

1.



Fracture reduction and fixation to restore anatomical relationships.

2.

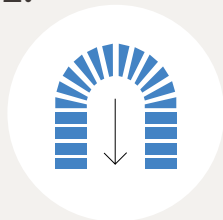

Fracture fixation providing absolute or relative stability, as required by the “personality” of the fracture, the patient, and the injury.

3.



Preservation of the blood supply to soft-tissues and bone by gentle reduction techniques and careful handling.

4.



Early and safe mobilization and rehabilitation of the injured part and the patient as a whole.

¹ Müller ME, Allgöwer M, Schneider R, Willenegger H. Manual of Internal Fixation. 3rd ed. Berlin, Heidelberg New York: Springer 1991.

² Buckley RE, Moran CG, Apivatthakakul T. AO Principles of Fracture Management: 3rd ed. Vol. 1: Principles, Vol. 2: Specific fractures. Thieme; 2017.

Preoperative Planning

Complete the preoperative radiographic assessment and prepare the preoperative plan.

■ **Note:**

When selecting the nail size, consider canal diameter, fracture pattern, patient anatomy and post-operative protocol.

Patient Positioning

Position the patient supine on an extension table or a radiolucent operating table. Abduct the unaffected leg as far as possible and place it on a leg support, so that it allows free fluoroscopic examinations. This should be tested preoperatively.

For unimpeded access to the medullary cavity, abduct the upper body by about 10–15° to the unaffected side (or adduct the affected leg by 10–15°).



Preparation

1. Reduce fracture

- ① Perform closed reduction of the fracture under image intensifier control. If the result is not satisfactory, perform open reduction.

▲ Precautions:

- Instruments and screws may have sharp edges or moving joints that may pinch or tear user's glove or skin.
- Handle devices with care and dispose worn bone cutting instruments in an approved sharps container.

2. Confirm nail length and diameter

Instrument

309.602 Radiographic Ruler for PFNA

The required nail length must be determined after reduction of the femoral fracture.

- 1 Position the C-arm for an AP view of the proximal femur. With long forceps, hold the ruler alongside the lateral thigh, parallel to and at the same level as the femur. Adjust the ruler until the proximal end is at the desired nail insertion position. Mark the skin at the proximal end of the ruler.
- 2 Move the C-arm distally. Align the proximal end of the radiographic ruler to the skin mark, and take an AP image of the distal part. Verify fracture reduction going from proximal to the fracture to distal.

Read the nail length directly from the ruler image. For long nails, select the measurement at or just proximal to the epiphyseal scar, or at the chosen insertion position.

Note:

When selecting the nail size, consider canal diameter, fracture pattern, patient anatomy and post-operative protocol.

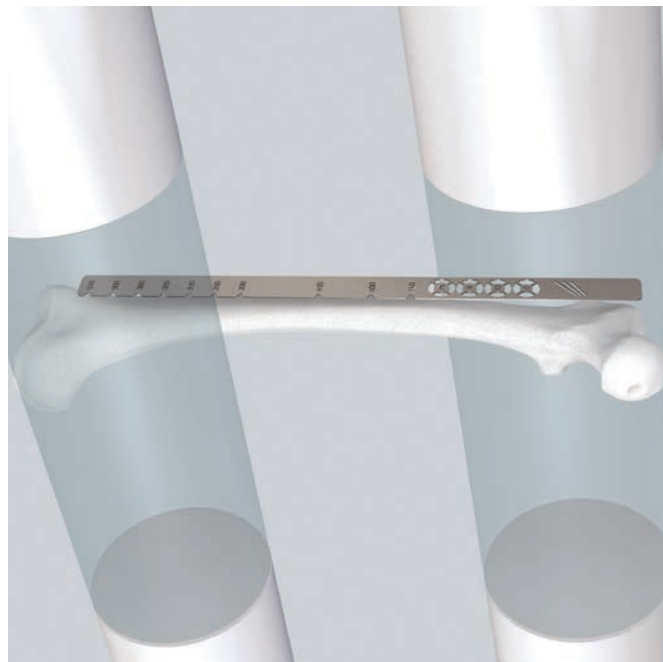

Alternatives

Determine the nail length by the procedure above on the uninjured leg before draping (unsterile) or compare the length of two identical SynReam reaming rods \varnothing 2.5 mm (352.032) or use the depth gauge (351.717 and 351.719) in combination with the SynReam reaming rod \varnothing 2.5 mm, length 950 mm (352.032) before inserting the PFNA-II nail.

Place the Radiographic Ruler for PFNA (309.602) perpendicular to the femur axis so that the diameter gauge is located over the isthmus. Select the nail diameter with which the intramedullary canal-to-cortex transition is still visible on both sides of the diameter gauge.

The ruler provides only an estimate of the canal diameter as it is not at the same level as the femur.

If the reamed technique is used, the diameter of the largest medullary reamer applied must be 0.5 mm to 1.5 mm larger than the nail diameter.

Always choose the largest diameter nail that fits into the intramedullary canal (\varnothing 9 mm nails should only be used for an intramedullary canal smaller than 11 mm).



3. Approach

Palpate the trochanter major.

Make a 5 cm incision proximal from the tip of the greater trochanter. Make a parallel incision of the fasciae of the gluteus medius and split the gluteus medius in line with the fibers.

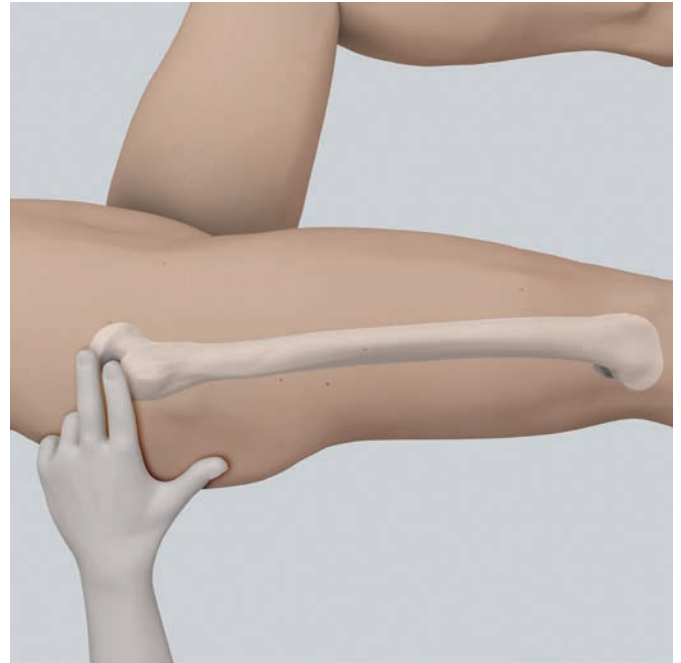

Open Femur

1. Determine entry point

- ❶ In AP view, the PFNA-II entry point is on the tip or slightly lateral to the tip of the greater trochanter in the curved extension of the medullary cavity, as the ML angle of the PFNA-II is 5°.
- ❷ In lateral view the entry point is in line with the axis of the intramedullary canal.

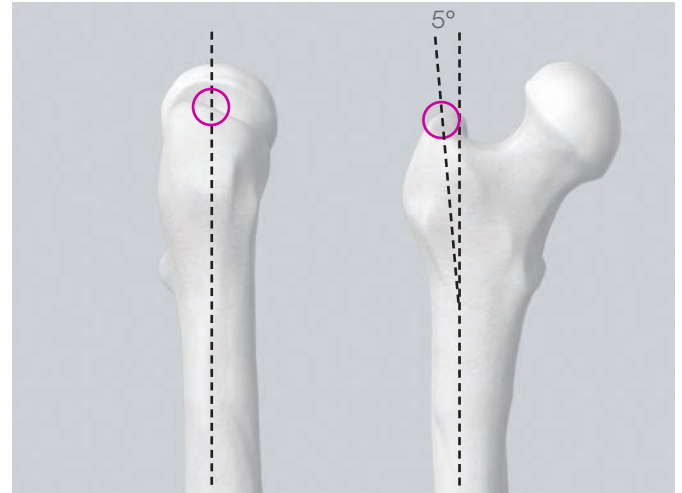

2. Insert guide wire

Instruments

356.830	Guide Wire Ø 3.2 mm, for PFNA Blade
393.100	Universal Chuck with T-Handle
03.023.002	Protection Sleeve 20.0/17.0, for PFNA-II
03.023.006	Drill Sleeve, for PFNA-II

Secure the guide wire in the power tool. Alternatively, the universal chuck with T-handle can be used to insert the guide wire manually.

Position both the protection sleeve and the drill sleeve at the insertion point. Insert the guide wire through the protection sleeve and the drill sleeve. Remove the power tool and the drill sleeve.



To correct the placement of the guide wire, leave the first guide wire in place and insert a second guide wire through one of the multiple holes of the drill sleeve.

■ **Note:**

The correct entry point and angle are essential for a successful result. To ensure the correct position of the guide wire, position a guide wire ventrally on the femur and check under image intensifier control.

Alternative

Instruments

356.830	Guide Wire Ø 3.2 mm, for PFNA Blade
393.100	Universal Chuck with T-Handle
357.001	Protection Sleeve 20.0/17.0, for No. 357.005
309.603	Drill Sleeve 17.0/3.2, for No. 357.001

■ **Note:**

Use drill bit 309.600 only together with protection sleeve 357.001.

Secure the guide wire in the power tool. Alternatively, the universal chuck with T-handle can be used to insert the guide wire manually.

Position both protection sleeve and drill sleeve at the insertion point. Insert the guide wire through the protection sleeve and the drill sleeve. Remove the power tool and the drill sleeve.



3. Open femur with flexible drill bit

Instruments

03.023.010	Drill Bit Ø 16.5 mm, cannulated, flexible, for PFNA-II
03.023.002	Protection Sleeve 20.0/17.0, for PFNA-II
393.100	Universal Chuck with T-Handle

Guide the flexible cannulated drill bit through the protection sleeve over the guide wire and drill the cavity for the proximal part of the PFNA-II nail with the power tool. Remove the drill bit, the protection sleeve and the guide wire.

▲ Precaution:

It is recommended to open the femur by using a power tool at high speed or carefully by hand. To prevent dislocating the fracture fragments, avoid lateral movements or excessive compression forces.



Alternative: Open femur with awl

Instrument

03.023.003	Awl for PFNA-II
------------	-----------------

Guide the awl over the guide wire and prepare with bi-directional turns the cavity for the proximal part of the PFNA-II nail. Remove the awl and the guide wire.



Alternative: Open femur with drill bit

Instruments

309.600	Drill Bit Ø 17.0 mm, cannulated, for PFNA
357.001	Protection Sleeve 20.0/17.0, for No. 357.005
393.100	Universal Chuck with T-Handle

■ Note:

Use drill bit 309.600 only together with protection sleeve 357.001.

Guide the drill bit through the protection sleeve over the guide wire and drill as far as the stop on the protection sleeve. Remove the drill bit, the protection sleeve and the guide wire.

▲ Precaution:

It is recommended to open the femur by using a power tool at high speed or carefully by hand. To prevent dislocating the fracture fragments, avoid lateral movements or excessive compression forces.



4. Option: Ream medullary canal

Instruments

189.060/ 175.500	SynReam Intramedullary Reaming System
351.782	Holding Forceps for SynReam Reaming Rod \varnothing 2.5 mm

If necessary, enlarge the femoral canal to the desired diameter using the medullary reamer and the corresponding surgical technique.

- ⓘ Check fracture reduction under image intensifier control.

Insert reaming rod

Insert the reaming rod into the medullary canal to the desired insertion depth. The tip must be correctly positioned in the medullary canal since it determines the final distal position of the long PFNA-II.

Reaming

Starting with the 8.5 mm diameter reaming head, ream to a diameter of 0.5 to 1.5 mm greater than the nail diameter. Ream in 0.5 mm increments and advance the reamer with steady, moderate pressure. Do not force the reamer. Partially retract the reamer repeatedly to clear debris from the medullary canal.

Use the holding forceps to retain the reaming rod while reaming and to prevent it from rotating. Remove the reaming rod before locking the intramedullary nail.



Insert Nail

1. Assemble PFNA-II instruments

Instruments

03.010.405	Insertion Handle, radiolucent, for PFNA
357.029	Connecting Screw, cannulated, for PFNA
03.023.011	Screwdriver, hexagonal with spherical head \varnothing 10.0 mm, cannulated

Guide the connecting screw through the insertion handle and secure the desired PFNA-II to the insertion handle using the hexagonal screwdriver with spherical head.

▲ Precaution:

Ensure that the connection between PFNA-II and insertion handle is tight (retighten, if necessary) to avoid deviations when inserting the PFNA-II blade through the aiming arm. Do not attach the aiming arm yet.



2. Insert PFNA-II

- Use image intensifier control to insert the PFNA-II.

Carefully insert the PFNA-II manually using slight bidirectional turns of the insertion handle as far as possible into the femoral opening. If the PFNA-II cannot be inserted, select a smaller size PFNA-II diameter or ream the medullary cavity to a diameter that is at least 1 mm larger than that of the selected nail.

The correct PFNA-II insertion depth is reached as soon as the projected PFNA-II blade is positioned in the center of the femoral head. A too cranial or too caudal PFNA-II position should be avoided as it can lead to malposition of the PFNA-II blade.

The anteversion can be determined by inserting a guide wire ventral to the femoral neck in the femoral head. In the mediolateral view, place the insertion handle parallel to the guide wire to align the correct rotation of the PFNA-II.

Remove all guide wires.

▲ Precautions:

Guide wires are single-use items, do not re-use. Always ensure that the PFNA-II is firmly attached to the insertion handle.



Optional instruments

03.010.424	Connector for Insertion Handle for PFNA
03.010.124	Combined Hammer 500 g, can be mounted, for No. 357.117
357.071	Hammer Guide, for No. 357.026

Attach the connector on the insertion handle and use light hammer blows on the connector to insert the nail.

Remove the connector.

Optionally, instead of the connector, the hammer guide can be threaded into the insertion handle and the hammer can be used as a slide hammer.

Remove the hammer guide.

▲ **Precaution:**

Use only light blows on the connector for insertion handle. Avoid unnecessary use of force to prevent loss of reduction or an iatrogenic fracture.



Proximal Locking

1. Choose aiming arm for PFNA-II blade insertion

Instruments

03.010.406 Aiming Arm 125° for PFNA Blade

03.010.407 Aiming Arm 130° for PFNA Blade

03.010.470 Plug for Aiming Arm

Using the hexagonal screwdriver with spherical head, confirm that the connecting screw between the insertion handle and the PFNA-II is sufficiently tightened.

Mount the appropriate aiming arm based on the chosen CCD angle of the PFNA-II and fix it firmly to the insertion handle.

Insert the plug for aiming arm into the locking hole of the nail length that is NOT used in this case.



2. Prepare guide wire insertion

Instruments

356.817	Buttress/Compression Nut, for PFNA Blade
356.818	Protection Sleeve 16.0/11.0, for PFNA Blade
356.819	Drill Sleeve 11.0/3.2, for PFNA Blade
356.820	Trocar \varnothing 3.2 mm, for PFNA Blade, gold

Screw the buttress nut on the protection sleeve for PFNA blade. Make sure the “lateral side” marking points towards the head of the sleeve. Screw the buttress nut up to the marking on the protection sleeve.

Insert the drill sleeve and the trocar through the protection sleeve.

Advance the entire sleeve assembly for PFNA blade through the aiming arm to the skin until it clicks into the aiming arm. Adjust the position of the buttress nut if necessary.

▲ Precaution:

Ensure that the sleeve assembly clicks into the aiming arm, otherwise it will not guarantee the exact position of the PFNA-II blade.

Verify nail insertion depth and position for the helical blade/screw. Place a guide wire on the yellow marking of the aiming arm and radiographically check the guide wire position in AP.



3. Option: Position guide wire with aiming device

Instruments

03.010.412	Aiming Device for Guide Wire, for PFNA and TFN, for AP Orientation
03.010.414	Connecting Screw for PFNA, for No. 03.010.412

Attach the guide wire aiming device for AP orientation to the aiming arm using the connecting screw for PFNA.

- 1 Position the C-arm for the AP view. Rotate the C-Arm until any two orientation lines are symmetric to the protection sleeve.

The midline in between these two orientation lines predicts the location of the guide wire and PFNA-II Blade.

Adapt the insertion depth of the nail until the midline is centered in the femoral head.

The C-arm may be readjusted to make sure that two lines are symmetric to the sleeve.

Note:

The outer lines can be used to determine the center of the femoral head.



- Position the C-arm in the true lateral view (alignment of the axis of the femoral neck congruent with the axis of the femoral shaft).

Adjust nail rotation until the two lines on the insertion handle are symmetric to the PFNA-II nail.

Note:

A 3.2 mm guide wire can be inserted in the corresponding hole in the insertion handle to predict the location of the guide wire and PFNA-II blade.



4. Insert guide wire

Instrument

356.830 Guide Wire Ø 3.2 mm, for PFNA Blade

Make a stab incision in the area of the trocar tip. Advance the sleeve assembly through the soft tissues in direction of the lateral cortex.

Insert the sleeve assembly as far as the lateral cortex. Advance the protection sleeve to the lateral cortex using slight clockwise turns of the buttress nut. Prepare the passage of the protection sleeve by turning the internal drill sleeve.

Note:

The sleeve assembly must be in contact with the bone during the entire blade implantation. Do not tighten the buttress nut too firmly as this could impair the precision of the insertion handle and sleeve assembly.

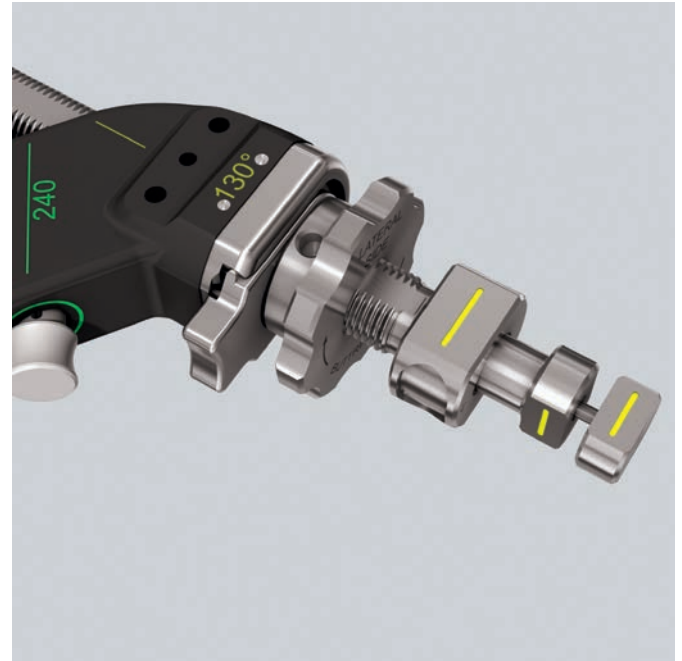

Incorrect position



Correct position

Mark the femur and remove the trocar. Insert a new guide wire through the drill sleeve into the bone. Verify both direction and position under image intensifier control in both AP and lateral view.

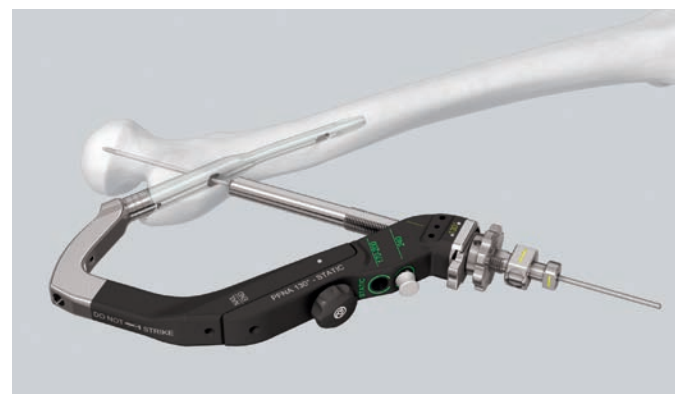

- ① In the AP and lateral view, the recommended position of the guide wire should be centered in relation to the femoral head. Insert the guide wire subchondrally into the femoral head at a distance of 10 mm below the joint level. Minimal distance to the joint is 5 mm. The tip of the guide wire is positioned at the intended blade tip position.

■ **Note:**

If the PFNA-II or the guide wire requires repositioning; remove the guide wire, release the sleeve assembly with buttress nut from the aiming arm by pressing the button on the clamp device, and remove it. The PFNA-II can be repositioned only by rotation, deeper insertion or partial retraction. Reinsert the sleeve assembly and turn the buttress nut clockwise to position the assembly on the bone. Introduce a new guide wire.

▲ **Precaution:**

Insert the guide wire for the PFNA-II blade carefully to avoid penetration into the joint.

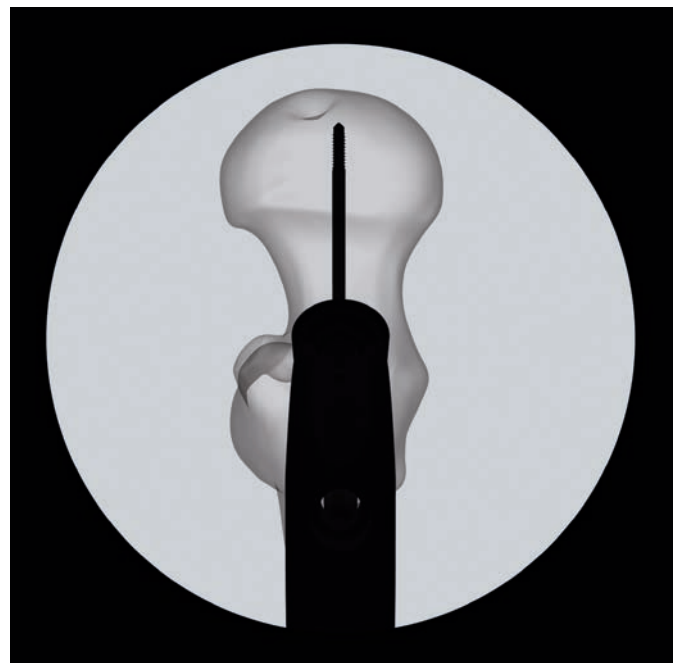
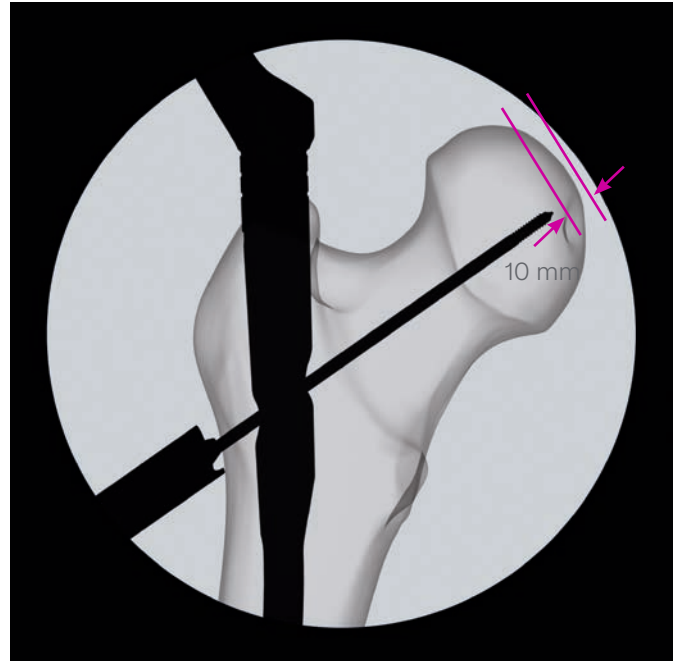

Optional technique for antirotation wires

Instruments

356.826	Aiming Jig for Anti-rotation Wire
356.827	Drill Sleeve 5.6/3.2, for No. 356.826
356.830	Guide Wire Ø 3.2 mm, for PFNA Blade

In very unstable fractures, insert an additional guide wire to prevent rotation. Leave the drill sleeve in place in the protection sleeve when applying this technique.

After having inserted the guide wire into the femoral head, secure the aiming jig for anti-rotation wire either anterior or posterior to the aiming arm. Secure the position of the anti-rotation wire by tightening the hexagonal nut.

Insert the drill sleeve into the aiming jig for anti-rotation wire. Make a stab incision and insert the drill sleeve to the bone.

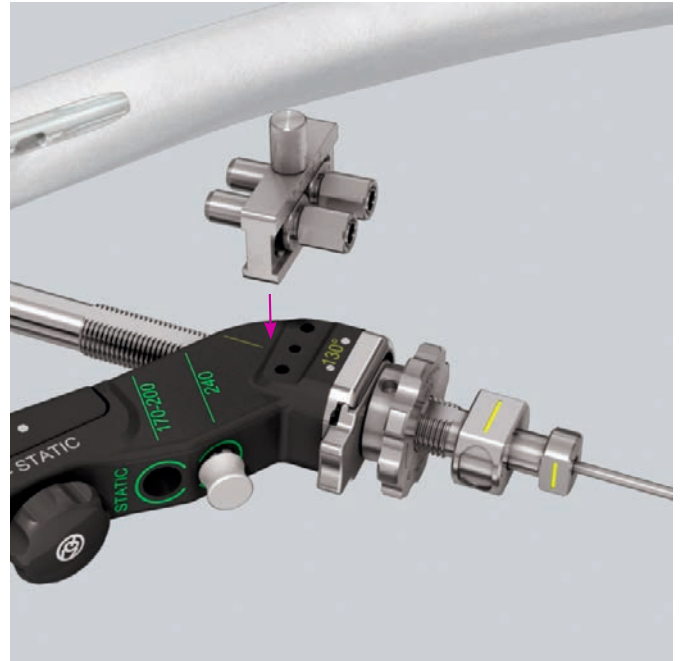

-
- ① Use image intensifier control to insert a guide wire into the femoral head. If a second anti-rotation wire is necessary, use the same procedure to insert it into the femoral head.

■ **Note:**

In axial view, the anti-rotation wire will approach, but not touch the blade tip. This anti-rotation wire fixes the femoral head only temporarily and will be removed after the insertion of the blade.



5. Measure the PFNA-II blade length

Instrument

356.829	Direct Measuring Device for Guide Wire Ø 3.2 mm
---------	--

- Verify the position of the guide wire in AP and lateral view before measuring the length.

Guide the measuring device over the guide wire. Advance the measuring device to the protection sleeve and determine the length of the required blade. The measuring device indicates the exact length of the guide wire in the bone.

In the AP and lateral view, the correct position of the PFNA-II blade is 10 mm below the joint level. Minimal distance to the joint is 5 mm. If the guide wire's position is subchondral, subtract 10 mm to measure the PFNA-II blade length correctly.

Remove the measuring device.

Carefully remove the drill sleeve without changing the position of the guide wire.

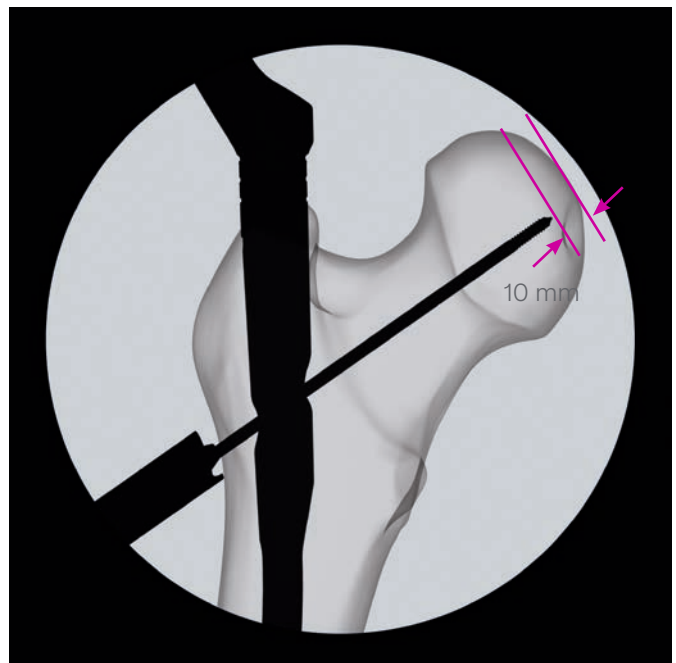

6. Open lateral cortex for PFNA-II blade insertion

Instrument

356.822 Drill Bit Ø 11.0 mm, for PFNA Blade

Push the cannulated drill bit over the 3.2 mm guide wire. Drill to the stop. This opens the lateral cortex.

▲ Precaution:

If the guide wire has been bent slightly during insertion, guide the drill bit over the wire using carefully forward and backward movements. However, if the wire has been bent to a greater extent, reinsert it or replace it by a new guide wire (see step 4). Otherwise, the guide wire may be advanced through the joint.



7. Drill hole for PFNA-II blade

Instruments

356.821	Reamer \varnothing 11.0 mm, for PFNA Blade
357.046	Fixation Sleeve, for No. 357.045

Note:

Use reamer only in a situation with good bone quality.

Set the chosen blade length on the cannulated reamer by fixing the fixation sleeve in the corresponding position. Read off the correct length on the side of the fixation sleeve pointing towards the tip of the reamer.

- Push the reamer over the guide wire. Monitor drilling under image intensifier control. Drill to the stop. The fixation sleeve prevents further drilling.

Precaution:

Use the reamer only after opening the lateral cortex. If the guide wire has been bent slightly during insertion, guide the reamer over the wire using carefully forward and backward movements. However, if the wire has been bent to a greater extent, reinsert it or replace it with a new guide wire (see step 4). Otherwise, the guide wire may be advanced through the joint.

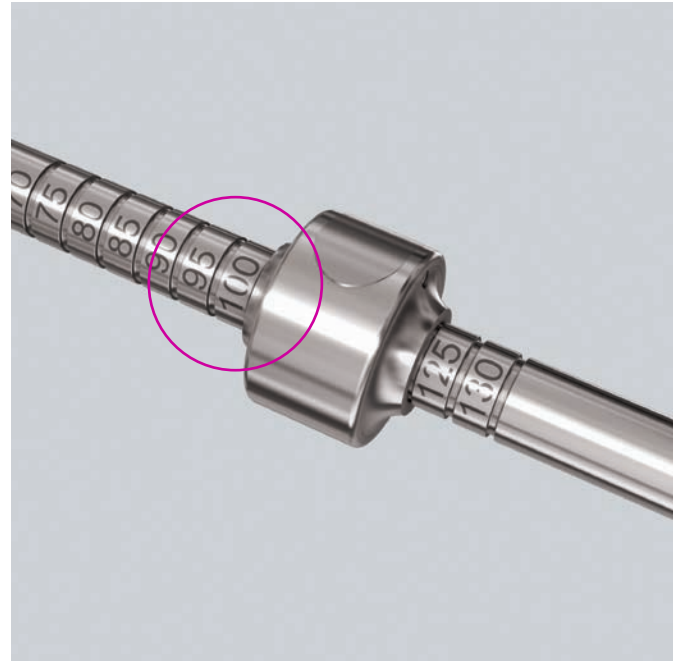

8. Assemble PFNA-II blade on the impactor

Instrument

03.010.410 Impactor for PFNA Blade

The PFNA-II blade is supplied in a locked state.

While attaching the PFNA-II blade on the impactor, screw the impactor counterclockwise (note the mark “attach” on the impactor) into the end of the PFNA-II blade to unlock the blade. Push the PFNA-II blade gently towards the impactor while attaching the PFNA-II blade. Do not over-tighten.

▲ Precaution:

The tip of the PFNA-II blade must rotate freely after attaching it to the impactor. This is essential for the implantation of the PFNA-II blade. Otherwise remove and dispose of the blade. Do not over tighten the connection between the impactor and the PFNA-II blade.

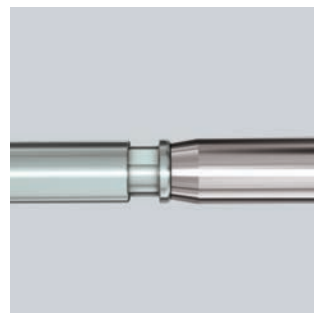
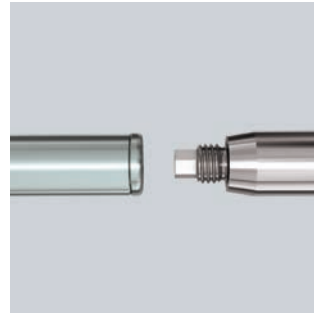

9. Insert PFNA-II blade

Instrument

03.010.124	Combined Hammer 500 g, can be mounted, for No. 357.117
------------	---

Insert the blade-impactor assembly over the guide wire. Push the button on the protection sleeve, align the blade (note marking on the protection sleeve) and advance the blade impactor assembly further through the protection sleeve.

Manually insert the blade over the guide wire advancing as far as possible into the femoral head.



Use monitoring during insertion of the PFNA-II blade.

Insert the PFNA-II blade to the stop by applying gentle blows with the hammer.

▲ Precaution:

Inserting the blade to the stop is important, as the impactor must click into the protection sleeve. Do not use unnecessary force when inserting the PFNA-II blade.

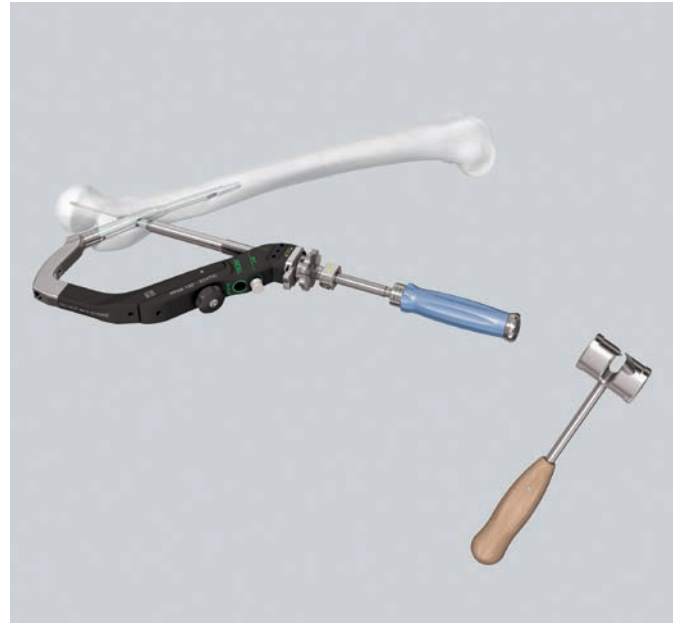

10. Lock PFNA-II blade

To lock the PFNA-II blade, turn the impactor clockwise (note “lock” marking on the handle) and tighten the blade.

- Verify PFNA-II blade locking intraoperatively. The PFNA-II blade is locked if all gaps are closed.

■ Note:

The gliding of the PFNA-II blade is guaranteed. If the PFNA-II blade cannot be locked, remove it and replace it with a new PFNA-II blade (see implant removal, step 1).

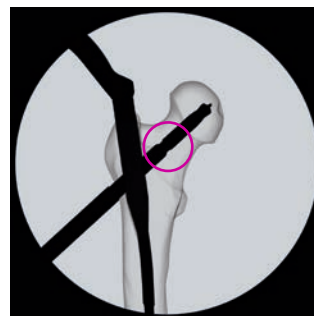
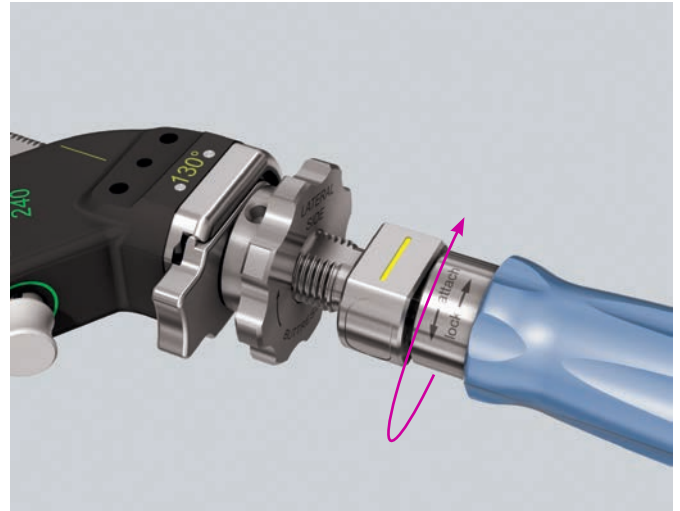

PFNA-II blade unlocked

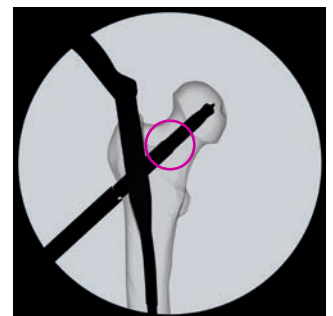

PFNA-II blade locked

Press the button on the protection sleeve to remove the impactor. Remove and dispose of the guide wire.

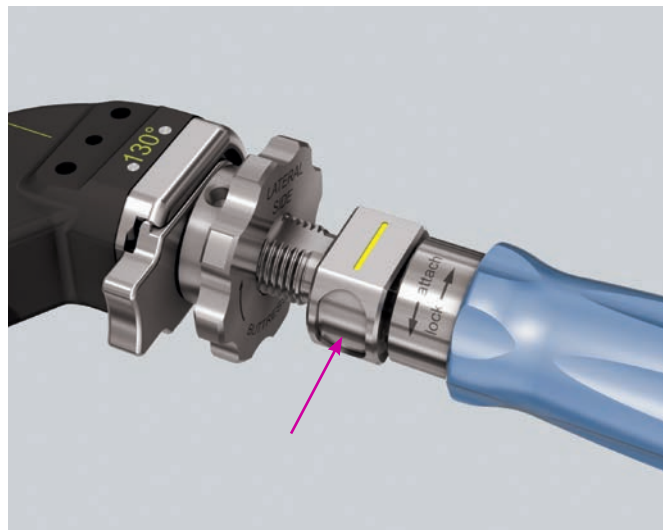

When proximal locking is complete, release and remove the protection sleeve and the buttress nut by pressing the button on the clamp device of the aiming arm in order to continue with distal locking or leave it in place to continue with intraoperative compression.

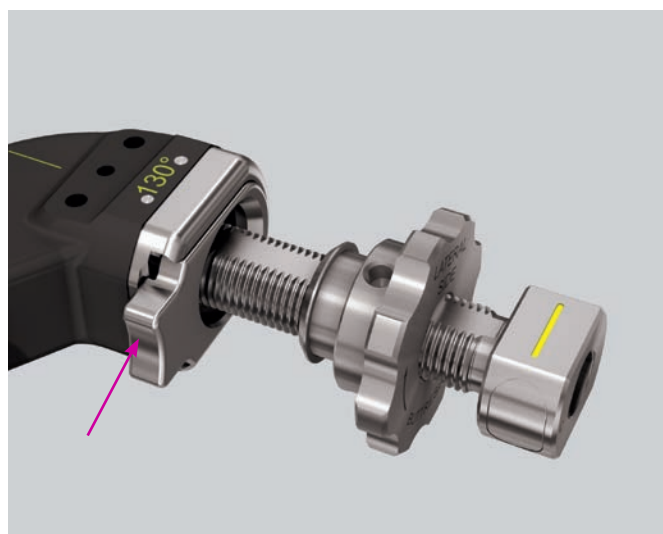

11. Option: Intraoperative compression

Instrument

03.010.423 Compression Instrument for
PFNA Blade

▲ Precaution:

Do not use intraoperative compression in osteoporotic bone.

Screw the compression instrument into the blade through the protection sleeve.

Turn the buttress nut counterclockwise to move the protection sleeve backwards until it is pushing towards the compression instrument.

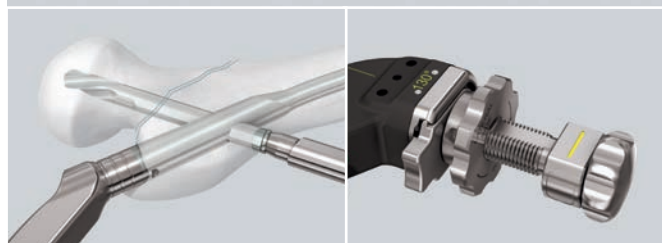
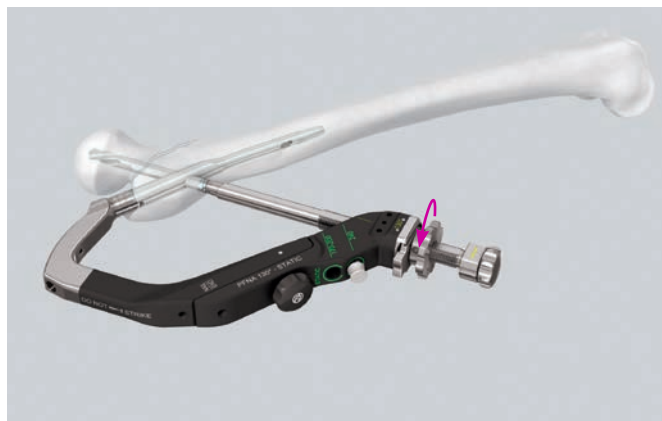
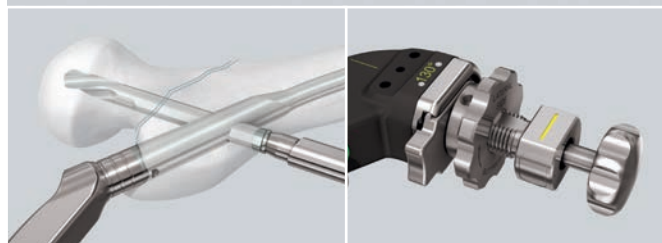
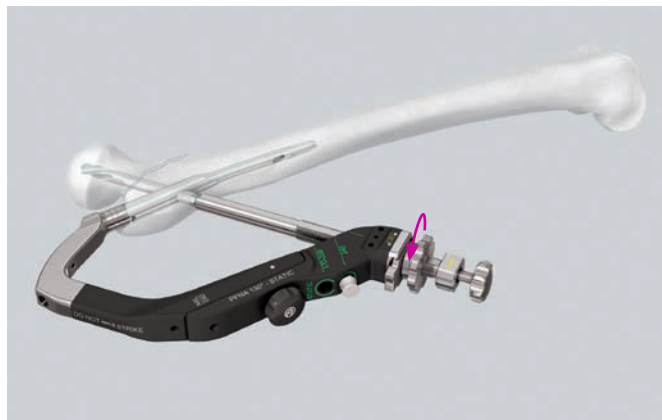

- Under image intensifier control, further turn the buttress nut counterclockwise to achieve intraoperative compression and close the fracture gap.

▲ Precautions:

- The blade must be locked to apply intraoperative compression.
- Control compression under image intensifier control.
- Do not use excessive force in order to avoid pulling out the blade from the femoral head.
- The blade may be slightly overinserted before applying intraoperative compression (see correction of insertion depth of PFNA-II blade) to prevent it from sticking out laterally.

Release strain by turning the buttress nut clockwise.

- Remove the compression instrument. Verify PFNA-II blade locking under image intensifier control. The PFNA-II blade is locked if all gaps are closed. If necessary, relock the blade using the extraction screw.

Release and remove the protection sleeve and the buttress nut by pressing the button on the clamp device of the aiming arm to continue with distal locking.

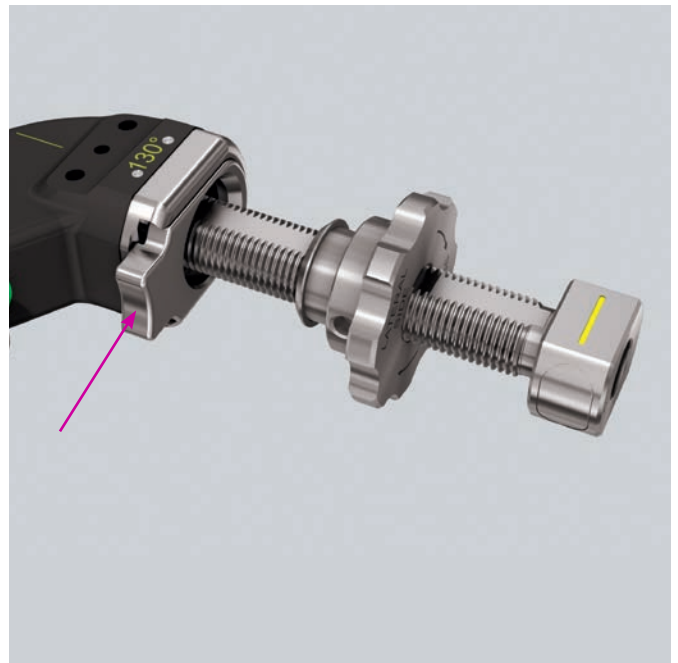
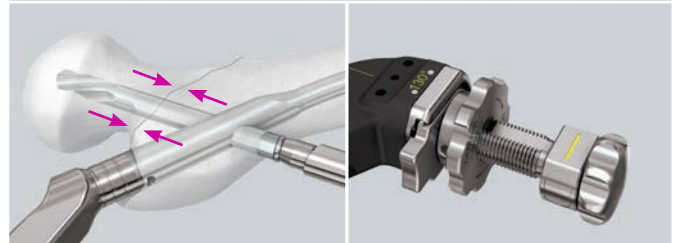
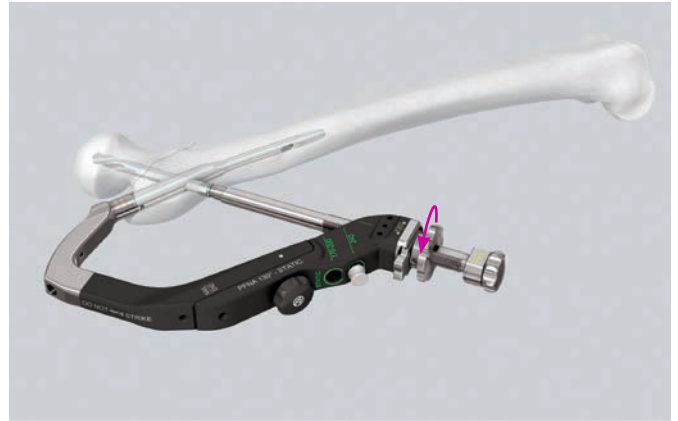

Distal Locking

Distal Locking for PFNA-II Short (Length 170 mm–240 mm)

Static or dynamic locking can be performed via the aiming arm with PFNA-II short (Length 170 mm–240 mm).

PFNA-II short

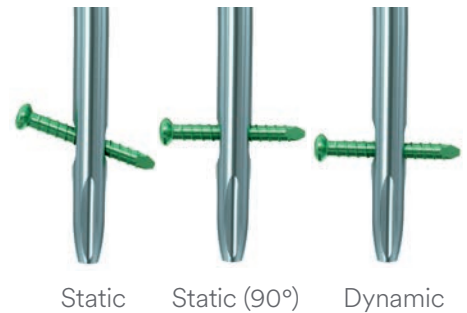

Distal Locking for PFNA-II Long (Length 260 mm–420 mm)

Distal locking of PFNA-II long is performed with the freehand technique. Alternatively distal locking can be performed using the SureLock System and the corresponding surgical technique.

PFNA-II long

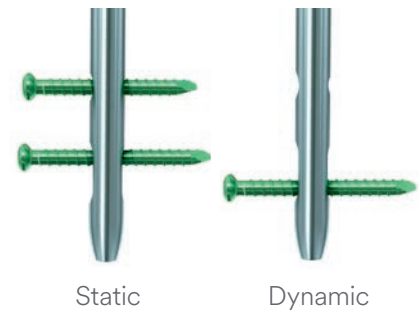

Locking implants for distal locking

Distal locking for PFNA-II described in this surgical technique is using the 4.9 mm locking bolts and the corresponding instruments (68.027.002.02: Insert 1, for Ø 4.9 mm locking bolts, from instrument set 01.027.101).

Alternatively, the 5.0 mm locking screws from the EXPERT Nailing Systems can be used with the corresponding instruments (68.027.002.03: Insert 1, for Ø 5.0 mm locking screws, from instrument set 01.027.102) for distal locking of the PFNA-II.

See table below for corresponding instruments.

Short PFNA-II Nails (170 mm–240 mm)

Locking Bolts Ø 4.9 mm		Locking Screws Ø 5.0 mm	
Part No.	Description	Part No.	Description
356.834	Drill Bit Ø 4.0 mm, for PFNA	03.010.061	Drill Bit Ø 4.2 mm, calibrated, length 340 mm, 3-flute, for Quick Coupling
356.831	Protection Sleeve 11.0/8.0, green	03.025.040	Protection Sleeve 11.0/8.0, length 188 mm
356.828	Drill Sleeve 8.0/4.0, green	03.010.065	Drill Sleeve 8.0/4.2
356.833	Trocar Ø 4.0 mm, green	03.010.070	Trocar Ø 4.2 mm
356.835	Measuring Device for Locking Bolt	03.010.428	Depth Gauge for Locking Screws, measuring range to 110 mm
314.260	Screwdriver, hexagonal, large, Ø 3.5 mm, with Groove, length 300 mm	03.010.107	Screwdriver STARDRIVE™, SD25, length 330 mm

Long PFNA-II Nails (260 mm–420 mm)

Locking Bolts Ø 4.9 mm		Locking Screws Ø 5.0 mm	
Part No.	Description	Part No.	Description
356.834	Drill Bit Ø 4.0 mm, for PFNA	03.010.101	Drill Bit Ø 4.2 mm, calibrated, length 145 mm, 3-flute, with Coupling for RDL
		03.010.104	Drill Bit Ø 4.2 mm, calibrated, length 145 mm, 3-flute, for Quick Coupling
356.835	Measuring Device for Locking Bolt	03.010.019	Depth Gauge for Locking Screws, measuring range up to 110 mm for No. 03.010.009
		03.010.429	Direct Measuring Device for Drill Bits, length 145 mm
314.260	Screwdriver, hexagonal, large, Ø 3.5 mm, with Groove, length 300 mm	03.010.362	Screwdriver STARDRIVE™, SD25, length 275 mm
314.280	Holding Sleeve, large	03.010.112	Holding Sleeve, with Locking Device

Distal Locking

For PFNA-II Short

Distal Locking for PFNA-II Short (Length 170 mm–240 mm)

1. Choose aiming arm for distal locking

Distal locking of PFNA-II short is performed through the aiming arm (see steps 2 and 3). Choose an appropriate aiming arm according to the table below. Make sure the plug for aiming arm is inserted into the locking hole of the nail length that is NOT used in this case.

Nail length	Locking	Aiming arm	
170 – 240 mm	Static	03.010.406	Aiming Arm 125° for PFNA Blade
170 – 240 mm	Static	03.010.407	Aiming Arm 130° for PFNA Blade
170 – 240 mm	Static (90°)	03.023.004	Aiming Arm for static locking, for PFNA-II
170 – 240 mm	Dynamic	03.010.409	Aiming Arm, for dynamic locking of PFNA

2. Option A: Static distal locking of PFNA-II short

Instruments

356.831	Protection Sleeve 11.0/8.0, green
356.828	Drill Sleeve 8.0/4.0, green
356.833	Trocar Ø 4.0 mm, green

Using the hexagonal screwdriver with spherical head, confirm that the connecting screw between the insertion handle and the PFNA-II is sufficiently tightened.

Insert the three-part trocar combination (protection sleeve, drill sleeve and trocar) through the hole in the aiming arm that corresponds with the nail length, make a stab incision and insert the trocar to the bone. Mark the femur and remove the trocar.



Option B: Static distal locking (90°) of PFNA-II short

Instruments

03.023.004	Aiming Arm for static locking, for PFNA-II
356.831	Protection Sleeve 11.0/8.0, green
356.828	Drill Sleeve 8.0/4.0, green
536.833	Trocar Ø 4.0 mm, green

Using the hexagonal screwdriver with spherical head, confirm that the connecting screw between the insertion handle and the PFNA-II is well tightened.

Remove the aiming arm for PFNA-II blade. Mount the aiming arm for static locking 90° and fix it firmly to the insertion handle.

Insert the three-part trocar combination (protection sleeve, drill sleeve and trocar) through the hole in the aiming arm that corresponds with the nail length, make a stab incision and insert the trocar to the bone. Mark the femur and remove the trocar.



Option C: Dynamic distal locking of PFNA-II short

Instruments

03.010.409	PFNA Aiming Arm for dynamic locking
356.831	Protection Sleeve 11.0/8.0, green
356.828	Drill Sleeve 8.0/4.0, green
356.833	Trocar Ø 4.0 mm, green

Using the hexagonal screwdriver with spherical head, confirm that the connecting screw between the insertion handle and the PFNA-II is well tightened.

Remove the aiming arm for PFNA-II blade. Mount the aiming arm for dynamic locking and fix it firmly to the insertion handle.

Insert the three-part trocar combination (protection sleeve, drill sleeve and trocar) through the hole in the aiming arm that corresponds with the nail length, make a stab incision and insert the trocar to the bone. Mark the femur and remove the trocar.



3. Drill

Instrument

356.834 Drill Bit Ø 4.0 mm, for PFNA

Use the drill bit to drill through both cortices. The tip of the drill bit should protrude by 2 to 4 mm.

- Just after drilling both cortices, confirm the drill bit position.

Ensure that the drill sleeve is pressed firmly to the near cortex and read the measurement from the calibrated drill bit at the back of the drill sleeve. This measurement corresponds to the appropriate length of the locking bolt. Remove the drill bit and the drill sleeve.

▲ Precaution:

Always make sure that no diastasis has occurred intraoperatively before beginning distal locking. Diastasis can cause delayed healing. Always ensure that the connection between PFNA-II, insertion handle and aiming arm is good, otherwise drilling for distal locking may damage the PFNA-II.

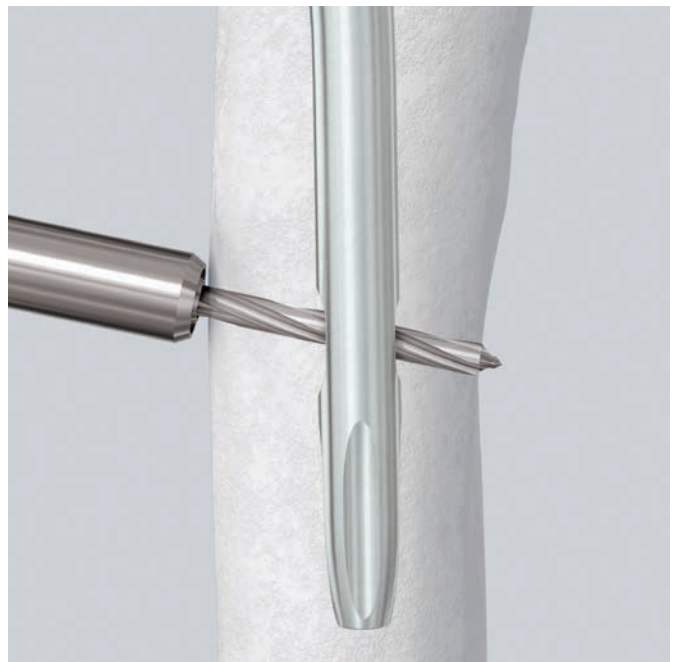

4. Option: Determine length of the locking bolt

Instrument

356.835 Measuring Device for Locking Bolt

After drilling both cortices, remove the drill bit and the drill sleeve.

Insert the depth gauge through the protection sleeve to the near cortex and advance the hook through both cortices. Draw back the hook until it engages in the opposite cortex. Read the measurement from the depth gauge. Add 2 to 4 mm to the measured length to ensure good engagement of the locking bolt in the opposite cortex.



5. Insert locking bolt

Instrument

314.260	Screwdriver, hexagonal, large, Ø 3.5 mm, with Groove, length 300 mm
---------	--

Insert a locking bolt of the measured length with the hexagonal screwdriver through the protection sleeve until the locking bolt head lies against the near cortex. The tip of the locking bolt should not project more than 1–2 mm beyond the far cortex.

Remove the screwdriver and the protection sleeve.



Distal Locking

For PFNA-II Long

Distal Locking for PFNA-II Long (Length 260 mm–420 mm)

1. Align C-arm

- 1 Check reduction, then correct alignment of the fragments and leg length before locking the nail.
- 2 Align the C-arm with the hole in the nail until a perfect circle is visible in the center of the screen.



2. Determine incision point

- 1 Place a guide wire on the skin over the center of the hole to mark the incision point and make a stab incision.



3. Drill

Instrument

511.417 Drill Bit \varnothing 4.0 mm with centering tip, length 148/122 mm, 3-flute, with Coupling for RDL

- 1 Using the radiolucent drive, under image intensification, insert the tip of the drill bit through the incision down to the bone.
- 2 Incline the drive in order that the tip of the drill bit is centered over the locking hole. The drill bit should almost completely fill the circle of the locking hole. Hold the drill bit in this position and drill through both cortices until the tip of the drill bit penetrates the medial far cortex.

Note:

For greater drill bit control, discontinue drill power after perforating the near cortex. Manually guide the drill bit through the nail before drilling the far cortex.



4. Determine length of the locking bolt and insert locking bolt

Instruments

356.835	Measuring Device for Locking Bolt
314.260	Screwdriver, hexagonal, large, \varnothing 3.5 mm, with Groove, length 300 mm
314.280	Holding Sleeve, large, for Nos. 314.190, 314.240, 314.260, 314.270 and 314.750

Measure the locking bolt length using the measuring device. Ensure that the outer sleeve is in contact with the bone and the hook grasps the far cortex. Add 2 to 4 mm to the measured length in order to ensure that the locking bolt is well engaged in the opposite cortex.

Insert the locking bolt with the appropriate length using the hexagonal screwdriver and the holding sleeve, if required.

- Verify the bolt length under image intensification. The bolt tip should be about 1–2 mm outside of the cortex. Exchange the locking bolt with the appropriate length if necessary.



Insert End Cap

1. Remove PFNA-II instruments

Instrument

03.023.011 Screwdriver, hexagonal with spherical head \varnothing 10.0 mm, cannulated

Remove the aiming arm. Loosen the connection screw with the hexagonal screwdriver with spherical head. Remove the connecting screw and the insertion handle.

■ Note:

The end cap with 0 mm extension can be inserted through the insertion handle barrel. Only remove the connecting screw and leave the insertion handle in place.



2. Insert end cap

Instruments

356.717	Guide Wire Ø 2.8 mm, length 460 mm, with Hook
03.023.001	Screwdriver STARDRIVE™ with spherical head, SD40, cannulated, length 300 mm

If the proximal end of the nail is flush with the upper edge of the trochanter major use the end cap with 0 mm extension. Use the end cap with 5 to 15 mm extension to lengthen the nail end.

Insert the hook of the guide wire through the selected end cap. Guide the cannulated screwdriver over the guide wire to the end cap. The end cap is retained automatically as soon as this connection is established.

Screw the end cap into the proximal end of the nail and tighten it firmly.

Remove the screwdriver and the guide wire.

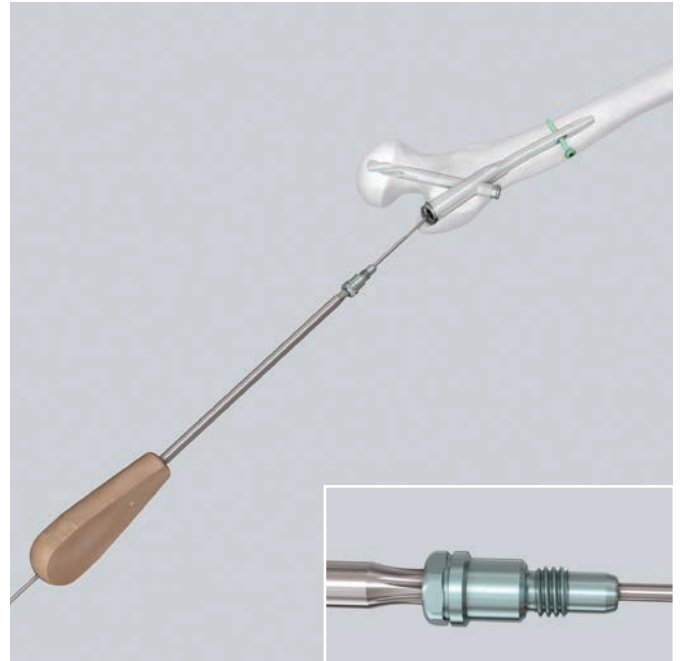

Implant Removal

1. Remove PFNA-II blade

Instruments

356.830	Guide Wire Ø 3.2 mm, for PFNA Blade
03.010.411	Extraction Screw for PFNA Blade
03.010.124	Combined Hammer 500 g, can be mounted
356.832	Key for PFNA Blade

Note:

Implant removal is an elective procedure. After an incision through the old scars, locate the PFNA-II blade by palpation or under image intensifier control. Insert the guide wire through the cannulated PFNA-II blade. Push the extraction screw over the guide wire and use gentle pressure to screw it counterclockwise into the PFNA-II blade (note “attach” marking on the extraction screw shaft).

Extract the PFNA-II blade by applying gentle blows with the hammer.

Notes:

- If the extraction of the PFNA-II blade is difficult, remove the locking bolt and the end cap, screw the hammer guide into the PFNA-II and mobilize the nail to loosen the nail-blade connection.
- To detach the blade from the bone use light hammer blows to slightly drive in the blade before removal of the blade.



Use the key for PFNA blade to detach the blade from the extraction screw if necessary.

■ **Note:**

If the removal of the PFNA-II blade is not possible with the standard instruments use the special instruments from the PFNA/PFNA-II Blade Extraction Set and the corresponding surgical technique.

2. Remove end cap

Instruments

356.717	Guide Wire Ø 2.8 mm, length 460 mm, with Hook
356.715	Socket, hexagonal, Ø 11.0/11.0 mm, cannulated, for AFN
321.160	Combination Wrench Ø 11.0 mm

Insert the hook of the guide wire with hook through the end cap. Guide the cannulated hexagonal socket over the guide wire to the end cap. Remove the end cap with the combination wrench.



3. Remove locking bolt and nail

Instruments

357.071	Hammer Guide, for No. 357.026
314.260	Screwdriver, hexagonal, large, Ø 3.5 mm, with Groove, length 300 mm
314.280	Holding Sleeve, large, for Nos. 314.190, 314.240, 314.260, 314.270 and 314.750
03.010.124	Combined Hammer 500 g, can be mounted

Before removing the locking bolt, screw the hammer guide into the PFNA-II and tighten it.

Remove the locking bolt with the hexagonal screwdriver. Mount the large holding sleeve onto the hexagonal screwdriver to facilitate removal of the locking bolt.

■ Note:

If removal of the locking bolt is not possible and/or in case of broken locking bolts, the Screw Extraction Set and the corresponding surgical technique is recommended.

Extract the nail by applying gentle blows with the hammer.

■ Notes:

- Remove the locking bolt after screwing the hammer guide into the PFNA/PFNA-II. Thereby a rotation of the PFNA/PFNA-II in the bone will be avoided.
- If the removal of the nail is not possible with the standard instruments use the special instruments from the Proximal Femoral Nail Removal Set for PFN™, TFN and PFNA/PFNA-II (01.010.180) and refer section “Broken Nail Removal”.



Broken Nail Removal

Alternative Technique – Extraction Hook For removal of broken nail

Instruments

355.399*	Extraction Hook Ø 3.7 mm, for Cannulated Nails
393.100	Universal Chuck with T-Handle
or	
393.105	Universal Chuck, small, with T-Handle

Begin with Steps 1 and 2 of Implant Removal, then remove the extraction screw from the nail.

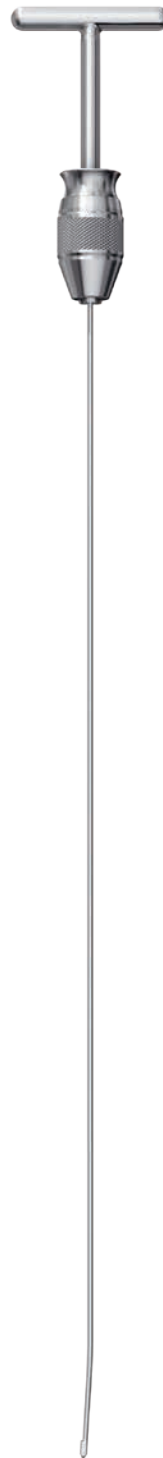

* Available nonsterile or sterile-packed.
Add "S" to catalog number to order sterile product.

Option 1

1. Assemble extraction hook and universal chuck

Insert the extraction hook into the universal chuck with T-handle. The hook should be parallel with the T-handle. This facilitates visualization of the hook position in the bone.

2. Insert extraction hook through nail

Pass the extraction hook through the cannula of the nail, including the distant fragment.

■ **Note:**

Under image intensification, verify that the hook has passed through and engaged the distant end of the nail.

3. Extract nail

Extract both nail fragments.

■ **Note:**

Keep the patient's limb restrained to increase the efficiency of the extraction force.

Option 2

1. Remove near nail fragment

Attach the appropriate extraction bolt or extraction screw to the nail. Remove the near nail fragment using the extraction bolt or extraction screw.

■ **Note:**

The extraction hook can be used as an alternative to extraction instrumentation.

2. Ream canal

Ream the medullary canal 1 mm larger than the nail diameter to clear a path for the distant nail fragment.

3. Align extraction hook

Insert the extraction hook and explanted near nail fragment into the medullary canal. The near nail fragment aligns the extraction hook with the cannulation of the distant nail fragment.

4. Engage distant fragment

Pass the extraction hook through the cannula of the distant nail fragment.

■ **Note:**

Under image intensification, verify that the hook has passed through and engaged the distant end of the nail.



5. Extract nail

Extract both nail fragments.

■ **Note:**

Keep the patient's limb restrained to increase the efficiency of the extraction force

Correction of Insertion Depth of PFNA-II Blade

Instruments

03.010.411	Extraction Screw for PFNA-II Blade
03.010.124	Combined Hammer 500 g, can be mounted

Remove the impactor if it is still in place. Insert the extraction screw over the guide wire and through the sleeve assembly using gentle counterclockwise pressure to attach the extraction screw to the PFNA-II blade (note “attach” marking).

Advance the now unlocked PFNA-II blade to the desired insertion depth by applying gentle blows with the combined hammer. In the AP and lateral view, the correct position of the PFNA-II blade is 10 mm below the joint level. Minimal distance to the joint is 5 mm. Turning the extraction screw clockwise to the stop (note “lock” marking) allows for relocking of the PFNA-II blade and removing the extraction screw.

- ① Verify PFNA-II blade locking intraoperatively.

■ Note:

The PFNA-II blade is locked if all gaps are closed.

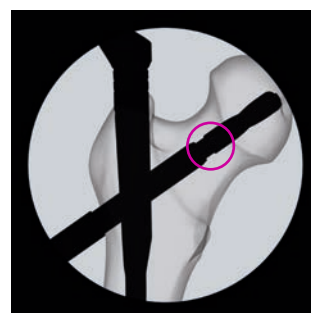
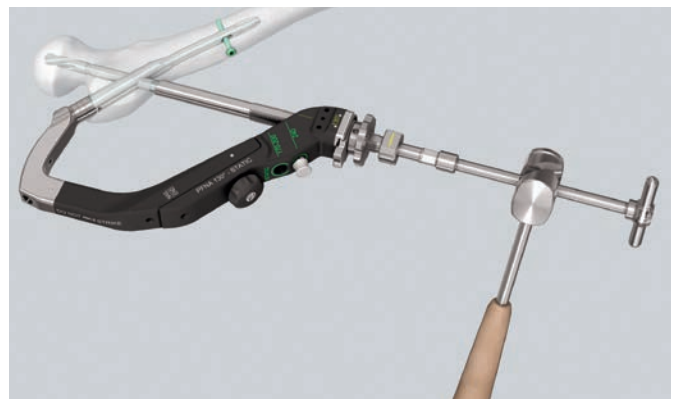

Cleaning

Intra- and postoperative cleaning

Instruments

319.460	Cleaning Stylet \varnothing 2.8 mm, for Cannulated Instruments
357.009	Cleaning Stylet \varnothing 2.8 mm, length 450 mm, for Cannulated Instruments



Use the 2.8 mm stylet or the long 2.8 mm cleaning stylet (length 450 mm) for intraoperative cleaning of the instrument cannulations.

Implants

PFNA-II Nails

Material:	Titanium alloy* (TAN)
Color:	Aqua
Diameters:	Ø 9 to Ø 12 mm (short nails, 1 mm increments) Ø 9 and Ø 10 mm (long nails) All nails have a proximal diameter of 16.5 mm with a lateral flattened surface
Lengths short Nails:	170 mm XS 200 mm Small 240 mm (one nail for left and right)
Lengths long Nails:	260 mm–340 mm (with 20 mm increments) 340 mm–420 mm (with 40 mm increments, only Ø 10 mm nails) (left and right nails)
CCD-Angle:	125° and 130°
Cannulation:	All nails are cannulated



*Ti-6Al-7Nb

PFNA-II XS, Length 170 mm, Titanium Alloy (TAN)

Distal Diameter (mm)	Angle	Length 170 mm
9	125°	472.100S
10	125°	472.101S
11	125°	472.102S
12	125°	472.103S
9	130°	472.104S
10	130°	472.105S
11	130°	472.106S
12	130°	472.107S

PFNA-II Small, Length 200 mm, Titanium Alloy (TAN)

Distal Diameter (mm)	Angle	Length 200 mm
9	125°	472.110S
10	125°	472.111S
11	125°	472.112S
12	125°	472.113S
9	130°	472.114S
10	130°	472.115S
11	130°	472.116S
12	130°	472.117S

PFNA-II, Length 240 mm, Titanium Alloy (TAN)

Distal Diameter (mm)	Angle	Length 240 mm
9	125°	473.800S
10	125°	473.801S
11	125°	473.802S
12	125°	473.803S
9	130°	473.804S
10	130°	473.805S
11	130°	473.806S
12	130°	473.807S



PFNA-II Nail Long, Titanium alloy (TAN)

Length (mm)	Angle	Ø 9 mm right	Ø 9 mm left
260	125°	473.060S	473.070S
280	125°	473.062S	473.072S
300	125°	473.035S	473.031S
320	125°	473.064S	473.074S
340	125°	473.037S	473.033S

Length (mm)	Angle	Ø 9 mm right	Ø 9 mm left
260	130°	473.061S	473.071S
280	130°	473.063S	473.073S
300	130°	473.036S	473.032S
320	130°	473.065S	473.075S
340	130°	473.038S	473.034S

Length (mm)	Angle	Ø 10 mm right	Ø 10 mm left
260	125°	473.040S	473.050S
280	125°	473.042S	473.052S
300	125°	473.015S	473.023S
320	125°	473.044S	473.054S
340	125°	473.017S	473.025S
380	125°	473.019S	473.027S
420	125°	473.021S	473.029S

Length (mm)	Angle	Ø 10 mm right	Ø 10 mm left
260	130°	473.041S	473.051S
280	130°	473.043S	473.053S
300	130°	473.016S	473.024S
320	130°	473.045S	473.055S
340	130°	473.018S	473.026S
380	130°	473.020S	473.028S
420	130°	473.022S	473.030S



PFNA-II Blades

Material:	Titanium Alloy* (TAN), color: aqua
Lengths:	75–120 mm (5 mm increments)
Cannulation:	All blades are cannulated



PFNA-II Blades

Length (mm)	TAN
75	04.027.050S
80	04.027.051S
85	04.027.052S
90	04.027.053S
95	04.027.054S
100	04.027.055S
105	04.027.056S
110	04.027.057S
115	04.027.058S
120	04.027.059S

*Ti-6Al-7Nb

PFNA-II End Caps

Used to protect nail threads from tissue ingrowth

Material: Titanium Alloy* (TAN), color: aqua

Lengths: 0 mm – sits flush with end of nail
5, 10 and 15 mm extensions –
extend nail height if nail is overinserted

Cannulation: All end caps are cannulated

Design: STARDRIVE SD40/hexagonal recess
Ø 11 mm



PFNA-II End Caps

Extension (mm)	TAN
----------------	-----

0	04.027.005S
---	-------------

5	04.027.006S
---	-------------

10	04.027.007S
----	-------------

15	04.027.008S
----	-------------

*Ti-6Al-7Nb

Locking Bolts

Material:	Titanium alloy* (TAN), color: light green
Drill:	Ø 4 mm
Lengths:	16–60 mm (2 mm increments) 60–80 mm (4 mm increments) 80–100 mm (5 mm increments)
Design:	Hexagonal recess Ø 3.5 mm



Locking Bolts Ø 4.9 mm, self-tapping

Length (mm)	TAN**
26	459.260
28	459.280
30	459.300
32	459.320
34	459.340
36	459.360
38	459.380
40	459.400
42	459.420
44	459.440
46	459.460
48	459.480
50	459.500
52	459.520

Length (mm)	TAN**
54	459.540
56	459.560
58	459.580
60	459.600
64	459.640
68	459.680
72	459.720
76	459.760
80	459.800
85	459.850
90	459.900
95	459.950
100	459.960

*Ti-6Al-7Nb

**Available non-sterile or sterile packed. Add "S" to the article number to order sterile products.

Alternative Implants

PFNA-II End Caps

Used to protect nail threads from tissue ingrowth

Material: Titanium Alloy* (TAN), color: aqua

Lengths: 0 mm – sits flush with end of nail
5, 10 and 15 mm extensions – extend nail height if nail is overinserted

Cannulation: All end caps are cannulated

Design: Hexagonal recess \varnothing 4.0 mm / \varnothing 1.0 mm



PFNA-II End Caps

Extension (mm)	TAN
----------------	-----

0	473.170S
---	----------

5	473.171S
---	----------

10	473.172S
----	----------

15	473.173S
----	----------

*Ti-6Al-7Nb

Locking Screws

Material:	Titanium Alloy* (TAN), color: light green
Drill:	Ø 4.2 mm
Lengths:	26 mm–80 mm (2 mm increments) 85 mm–100 mm (5 mm increments)
Design:	STARDRIVE SD25 recess



Locking Screws STARDRIVE™ Ø 5.0 mm, for Medullary Nails









Length (mm)	TAN**
26	04.005.516
28	04.005.518
30	04.005.520
32	04.005.522
34	04.005.524
36	04.005.526
38	04.005.528
40	04.005.530
42	04.005.532
44	04.005.534
46	04.005.536
48	04.005.538
50	04.005.540
52	04.005.542
54	04.005.544
56	04.005.546







Length (mm)	TAN**
58	04.005.548
60	04.005.550
62	04.005.552
64	04.005.554
66	04.005.556
68	04.005.558
70	04.005.560
72	04.005.562
74	04.005.564
76	04.005.566
78	04.005.568
80	04.005.570
85	04.005.575
90	04.005.580
95	04.005.585
100	04.005.590











*Ti-6Al-7Nb





**Available non-sterile or sterile packed. Add "S" or "TS" to the article number to order sterile products.

Instruments

309.602	Radiographic Ruler for PFNA	
314.050	Screwdriver, hexagonal, cannulated, for Cannulated Screws Ø 6.5 and 7.3 mm	
314.260	Screwdriver, hexagonal, large, Ø 3.5 mm, with Groove, length 300 mm	
314.280	Holding Sleeve, large, for Nos. 314.190, 314.240, 314.260, 314.270 and 314.750	
321.160	Combination Wrench Ø 11.0 mm	
321.170	Pin Wrench Ø 4.5 mm, length 120 mm	
356.715	Socket, hexagonal, Ø 11.0/11.0 mm, cannulated, for AFN	
356.717	Guide Wire Ø 2.8 mm, length 460 mm, with Hook	
356.817	Buttress/Compression Nut, for PFNA Blade	

356.818	Protection Sleeve 16.0/11.0, for PFNA Blade	
356.819	Drill Sleeve 11.0/3.2, for PFNA Blade	
356.820	Trocar Ø 3.2 mm, for PFNA Blade, gold	
356.821	Reamer Ø 11 mm, for PFNA Blade	
356.822	Drill Bit Ø 11 mm, for PFNA Blade	
356.826	Aiming Jig for Anti-rotation Wire	
356.827	Drill Sleeve 5.6/3.2, for No. 356.826	
356.828	Drill Sleeve 8.0/4.0, green	
356.829	Direct Measuring Device, for Guide Wire Ø 3.2 mm	
356.830	Guide Wire Ø 3.2 mm, for PFNA Blade	
356.831	Protection Sleeve 11.0/8.0, green	

356.832	Key for PFNA Blade	
356.833	Trocar Ø 4.0 mm, green	
356.834	Drill Bit Ø 4.0 mm, for PFNA	
356.835	Measuring Device, for Locking Bolt	
357.029	Connecting Screw, cannulated, for PFN and PFNA	
357.046	Fixation Sleeve, for No. 357.045	
357.071	Hammer Guide, for No. 357.026	
393.100	Universal Chuck with T-Handle	
03.010.124	Combined Hammer 500 g, can be mounted, for No. 357.117	
03.010.405	Insertion Handle, radiolucent, for PFNA	

03.010.407	Aiming Arm 130° for PFNA Blade	
03.010.410	Impactor for PFNA Blade	
03.010.411	Extraction Screw for PFNA Blade	
03.010.423	Compression Instrument for PFNA Blade	
03.010.424	Connector for Insertion Handle for PFNA	
03.010.470	Plug for Aiming Arm	
03.023.001	Screwdriver STARDRIVE™ with spherical head, SD40, cannulated, length 300 mm	
03.023.002	Protection Sleeve 20.0/17.0, for PFNA-II	
03.023.006	Drill Sleeve, for PFNA-II	
03.023.010	Drill Bit Ø 16.5 mm, cannulated, flexible, for PFNA-II	
03.023.011	Screwdriver, hexagonal with spherical head Ø 10.0 mm, cannulated	

Optional instruments

309.600 Drill Bit \varnothing 17.0 mm, cannulated, for PFNA



309.603 Drill Sleeve 17.0/3.2, for No. 357.001



319.970 Screw Forceps, self-holding, length 85 mm



351.050 Tissue Protector



356.830S Guide Wire \varnothing 3.2 mm, for PFNA Blade, sterile



357.001 Protection Sleeve 20.0/17.0, for No. 357.005



357.009 Cleaning Stylet \varnothing 2.8 mm, length 450 mm, for Cannulated Instruments



03.010.019 Depth Gauge for Locking Screws, measuring range up to 110 mm, for No. 03.010.009



03.010.362 Screwdriver STARDRIVE™, SD25, length 275 mm



03.010.406 Aiming Arm 125° for PFNA Blade



03.010.408 Aiming Arm 135° for PFNA Blade



03.010.409 PFNA Aiming Arm for dynamic locking



03.010.412 Aiming Device for Guide Wire,
for PFNA and TFN, for AP Orientation



03.010.414 Connecting Screw for PFNA,
for No. 03.010.412



03.023.003 Awl for PFNA-II



03.023.004 Aiming Arm for static locking,
for PFNA-II small and extra-small



Alternative instruments

321.200 Ratchet Wrench for Nut, hexagonal, 11.0 mm



357.012 Insertion Handle for PFN



357.013 Thread Gland for Hammer Guide, for No. 357.012



357.020 Insertion Handle for PFN and PFNA



357.021 Connecting Screw for PFN, for No. 357.012







357.023 Wrench, hexagonal, with T-Handle, for No. 357.021



357.026 Slotted Hammer 400 g, can be mounted



357.027	Socket, hexagonal, with T-Handle, short	
357.028	Connector for PFN, for No. 357.020	
399.420	Hammer 500 g	
03.025.040	Protection Sleeve 11.0/8.0, length 188 mm	
03.010.061	Drill Bit \varnothing 4.2 mm, calibrated, length 340 mm, 3-flute, for Quick Coupling	
03.010.065	Drill Sleeve 8.0/4.2, for No. 03.010.063	
03.010.070	Trocar \varnothing 4.2 mm, for No. 03.010.065	
03.010.101	Drill Bit \varnothing 4.2 mm, calibrated, length 145 mm, 3-flute, with Coupling for RDL	
03.010.104	Drill Bit \varnothing 4.2 mm, calibrated, length 145 mm, 3-flute, for Quick Coupling	

03.010.107 Screwdriver STARDRIVE™, SD25,
length 330 mm



03.010.112 Holding Sleeve, with Locking Device



03.010.126 Wrench, hexagonal with T-handle



03.010.428 Depth Gauge for Locking Screws,
measuring range to 110 mm



03.010.429 Direct Measuring Device for Drill Bits,
length 145 mm



Cases

SynCases

01.027.110 Instrument Set for PFNA-II Locking Bolts
Ø 4.9 mm, in SynCase

68.027.013 Lid for SynCase No. 68.027.010



68.027.012 Insert 2 for Instruments for
PFNA/PFNA-II (part 1), for SynCase
No. 68.027.010

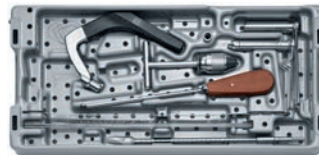

68.027.011 Insert 1 for Instruments for
PFNA/PFNA-II (part 1), for SynCase
No. 68.027.010



68.027.023 Lid for SynCase No. 68.027.020



68.027.022 Insert 2 for Instruments for
PFNA/PFNA-II (part 2),
for SynCase No. 68.027.020

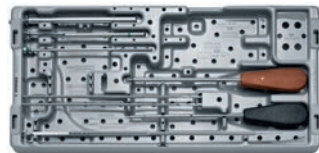

68.027.021 Insert 1 for Instruments for
PFNA/PFNA-II (part 2),
for SynCase No. 68.027.020

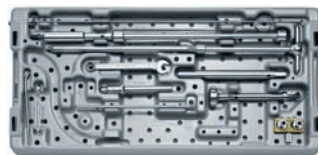

01.027.120 Instrument Set for PFNA-II Locking Screws \varnothing 5.0 mm, in SynCase

68.027.013 Lid for SynCase No. 68.027.010



68.027.012 Insert 2 for Instruments for PFNA/PFNA-II (part 1), for SynCase No. 68.027.010



68.027.011 Insert 1 for Instruments for PFNA/PFNA-II (part 1), for SynCase No. 68.027.010

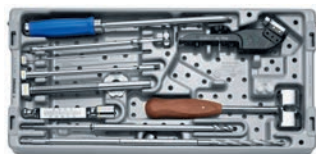

68.027.023 Lid for SynCase No. 68.027.020



68.027.022 Insert 2 for Instruments for PFNA/PFNA-II (part 2), for SynCase No. 68.027.020

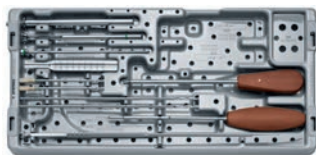

68.027.021 Insert 1 for Instruments for PFNA/PFNA-II (part 2), for SynCase No. 68.027.020

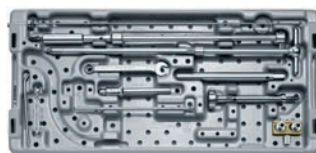

Vario Cases

01.027.101 Instrument Set for PFNA Locking Bolts
Ø 4.9 mm, in Vario Case

68.027.001 Vario Case for PFNA Instrument Set
(part 1), without Lid, without Contents

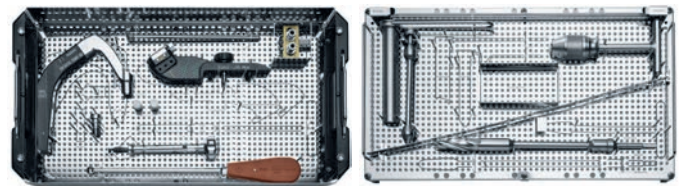

68.027.002 Vario Case for PFNA Instrument Set
(part 2), without Lid, without Contents

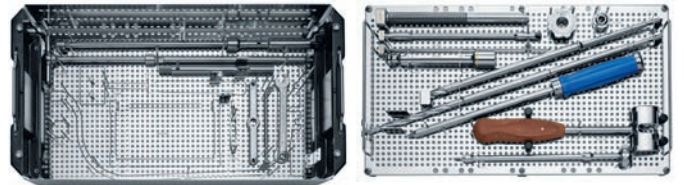

68.027.002.02 Insert 1, for Ø 4.9 mm Locking Bolts,
for PFNA Instrument Set (part 2),
for Vario Case No. 68.027.002

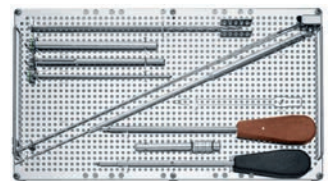

01.027.102 Instrument Set for PFNA Locking Screws \varnothing 5.0 mm, in Vario Case

68.027.001 Vario Case for PFNA Instrument Set (part 1), without Lid, without Contents

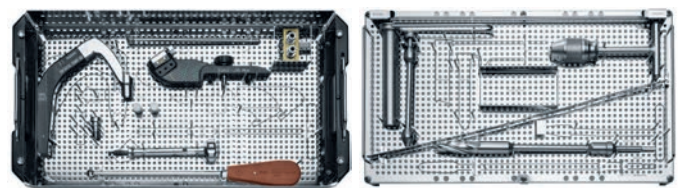

68.027.002 Vario Case for PFNA Instrument Set (part 2), without Lid, without Content

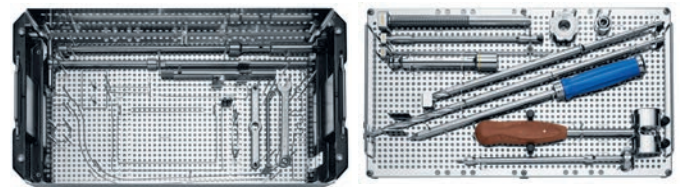

68.027.002.03 Insert 1, for \varnothing 5.0 mm Locking Screws, for PFNA Instrument Set (part 2), for Vario Case No. 68.027.002

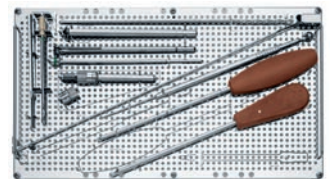

Optional

68.027.003 Rack for Locking Implants \varnothing 4.9 mm or \varnothing 5.0 mm, for Vario Case



689.507 Lid (Stainless Steel), size 1/1, for Vario Case



MRI Information

A patient implanted with the DePuy Synthes device may be safely scanned under the following conditions. Failure to follow these conditions may result in injury to the patient. The recommendations below only apply to the implantable devices and not to instrumentation.

Nominal values of Static Magnetic Field (Bo)	1.5 Tesla or 3 Tesla
Maximum Spatial Field Gradient (SFG)	Up to 20 T/m (2,000 gauss/cm) Note: 20 T/m is a standardized value often used in labeling
Static Magnetic Field (Bo) Orientation	Horizontal, Cylindrical Bore
RF Excitation	Circularly polarized
RF Transmit Coil Type	Transmit quadrature-driven coil only
Maximum Whole-body SAR	Normal Operating Mode or 2 W/kg for 1.5 T 2 W/kg for 3.0 T
Maximum expected temperature rise	9.5 °C in 1.5 T system 5.9 °C in a 3.0 T system
Limits on Scan Duration	1.5 T (64 MHz) environment – Scan for 6 minutes of continuous RF exposure with one or more MR imaging pulse sequences (scan or series) 3.0 T (128 MHz) environment – Scan for 15 minutes of continuous RF exposure with one or more MR imaging pulse sequences (scan or series)
MR Artifact	The presence of the device may produce an image artifact. Imaging protocol modifications may be necessary to compensate for the image artifact.

▲ Precautions:

The above-mentioned test relies on non-clinical testing. The actual temperature rise in the patient will depend on a variety of factors beyond the SAR and time of RF application. Thus, it is recommended to pay particular attention to the following points:

- It is recommended to thoroughly monitor patients undergoing MR scanning for perceived temperature and/or pain sensations.
- Generally it is recommended to use a MR system with low field strength in the presence of conductive implants. The employed specific absorption rate (SAR) should be reduced as far as possible.
- Using the ventilation system may further contribute to reduce temperature increase in the body.

Please refer to the corresponding Instructions for Use for specific information on Intended use, Indications, Contraindications, Warnings and Precautions, Potential Adverse Events, Undesirable Side Effect and Residual Risks. Instructions for Use are available at www.e-ifu.com and/or www.depuySynthes.com/ifu

Not all products are currently available in all markets.
This publication is not intended for distribution in the USA.



Synthes GmbH
Eimattstrasse 3
4436 Oberdorf
Switzerland
Tel: +41 61 965 61 11

www.jnjmedtech.com